

Technical data:

Heating fuel: _____

Inlet pressure p_e _____

Calorific value H_u _____

Electrics:

Voltage / frequency _____

Oxygen:

Inlet pressure p_e _____

Demand:

- Fast heating

$T =$ _____ °C

$t =$ _____ min

- Drying (monolithic lining)

Material: _____

$T =$ _____ °C

$t =$ _____ h

- Tempering (Bricks)

Material: _____

$T =$ _____ °C

$t =$ _____ h

Ladle lining:

Bottom: _____ m= _____ t

Wall: _____ m= _____ t

Slag area _____ m= _____ t

- Vertical ladle heater

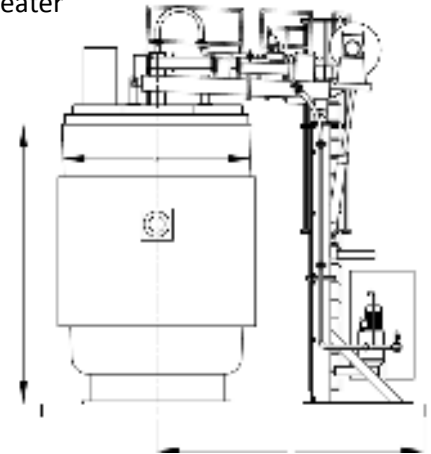

- Horizontal ladle heater

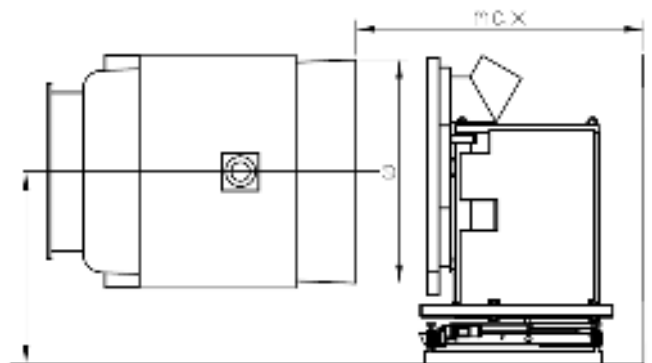

Existing heater:

- Small lid
 Big lid with gap
 Big lid without flexible suspension

T_{max} _____ °C

$t =$ _____ h

Remarks:

Limited Partnership:
 MEFKON GmbH & Co. KG
 Am Willrother Berg 5
 D-56594 Willroth
 www.mefkon.com

Managing Director:
 Renate Lorenz, Wolfgang Lorenz

Phone: + 49 2687 92627-0
 Fax: + 49 2687 92627-20
 E-mail: info@mefkon.com

Private Limited Company:
 MEFKON Verwaltungs GmbH

Sales Tax Identification No:
 DE815167832

Tax Identification No:
 02/201/00780

Commercial Register No:
 Montabaur, HRA 20886
 Montabaur, HRB 22046

Accounts:

VR-Bank Neuwied-Linz eG
 BLZ: 57460117, Konto: 1211344
 IBAN :DE 05574601170001211344, BIC: GENODED1NWD

Sparkasse Neuwied
 BLZ: 57450120, Konto: 30222392
 IBAN : DE 70574501200030222392, BIC: MALADE51NWD

Commerzbank Neuwied
 BLZ: 57040044, Konto: 281666800
 IBAN : DE 56570400440281666800, BIC: COBADEFF575